

Add-on module of the WANGEN Twin NG,
with hopper and screw conveyor

WANGEN VarioTwin NG

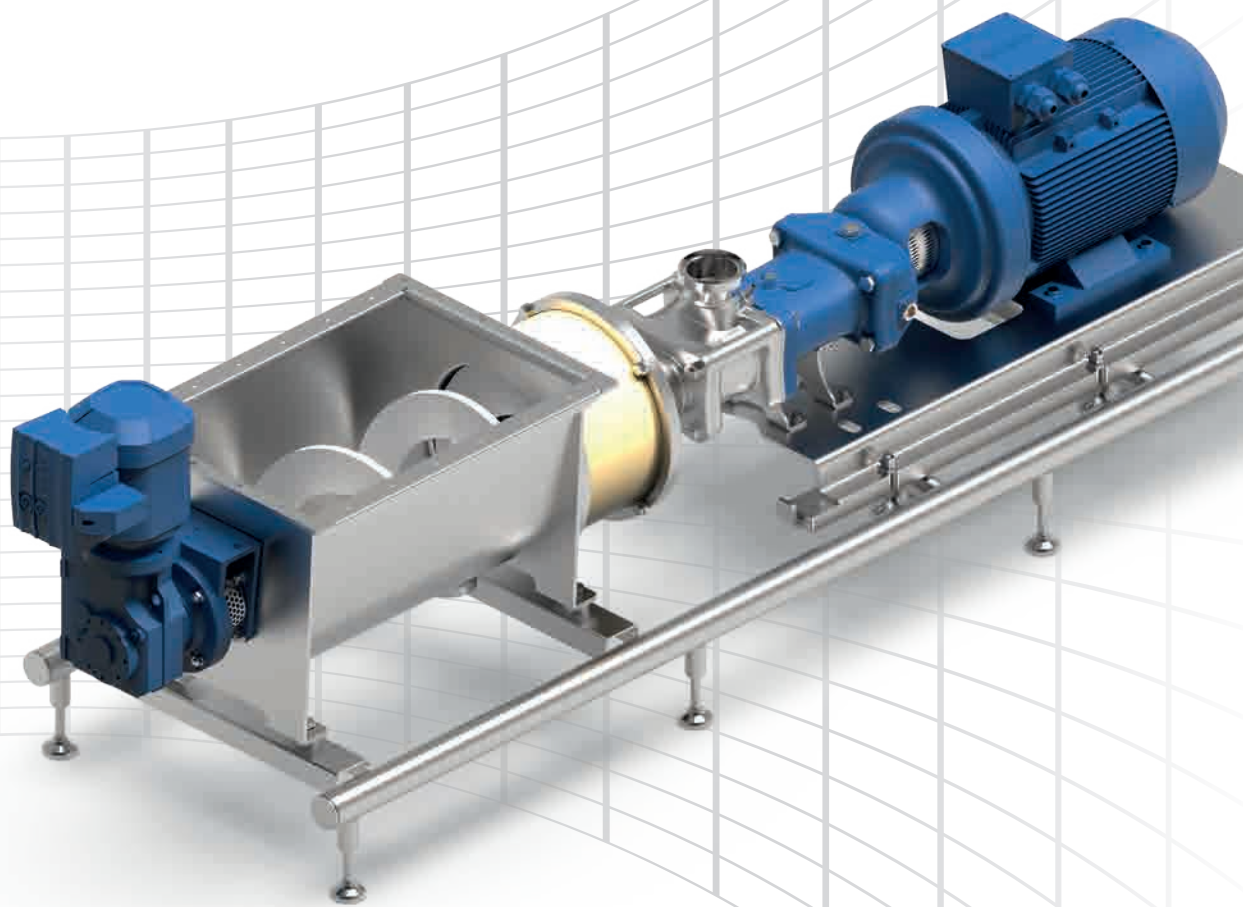

Gently feeding high-viscosity media:
The hygienic and patented add-on
to the WANGEN Twin screw pump.

Feed unit with hopper and screw conveyor

WANGEN VarioTwin NG

The VarioTwin is the ideal feeder unit to pump highly viscous, not flowable media for the series 104 and 130 of the WANGEN Twin NG. This is due to the forced conveying of the pumped media via the feed screw. To cover the widest possible range of applications, the length of the hopper can optionally be designed at various levels. Therefore, the name VarioTwin was chosen.

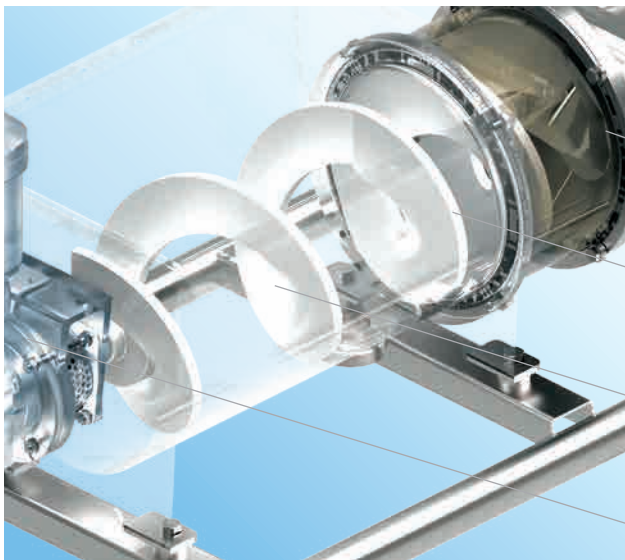

S-cone adapter element. Connects the feed unit with the WANGEN Twin. Suitable sizes for the Twin NG 104 and 130.

'Coreless' screw conveyor. Is able to return excess material. Particularly gentle feed. Simple, effective cleaning.

Hopper available in variable length, optimally balanced to meet the field of application and requirements.

Drive of feed screw in the hopper can be regulated separately.

Cross-section of the 'VarioTwin NG' hopper.

Product advantages:

- 'Coreless screw' for gentle product treatment of media.
- Hygiene-optimised design; therefore, minimal dead spaces. Enables easy and efficient cleaning.
- Cantilevered support system of the screw for maximum hygiene with minimal residues
- Low space requirement due to compact design.
- Drive independently controlled pump speed.
- Low energy consumption due to energy-efficient screw geometry.
- Materials are FDA-compliant, product-contacting parts in 1.4571/1.4404.

Technical highlights:

- Flowrate up to 10 m³/h
- Temperature up to +90 °C
- Viscosity up to 3.000.000 mPa·s



Applications

Conveying Materials

The WANGEN VarioTwin NG is suitable for pumping the following media:

- High-viscosity dough in the baking industry
- Fruit, such as strawberries, including frozen fruit
- Vegetables, such as potatoes
- High-viscosity chocolate mixture, waffle rework, marzipan and sugar mixtures (licorice, etc.)
- High-viscosity dairy products, such as curd
- Pulp-containing media, such as additives in food production
- High-viscosity soy products (okara)
- Meat-based products, such as raw mixture of reconstituted meat, minced meat, sausage meat or animal feed
- Fibre-containing extracts for the cosmetics industry (cream, ointment or soap)
- High-viscosity chemical products, such as anti-freezing agents, glues (including wood glue) or raw materials and pastes



Benefits

Characteristics

Due to the special design of the WANGEN VarioTwin NG's hopper, the proven, low dead-space concept of the Twin series is consistently broadened by further advantages.

When using hopper feed pumps, the media feed may be subjected to severe fluctuations. To balance the fluctuations, the 'coreless' feeder used in WANGEN pumps ensures a large buffer volume during media supply. At the front section of the feeder, excess material is returned by the axial feeder cavity to the rear section and thus balances the feed volume in the case of temporarily low material supply. This ensures a constant even filling during the feed process.

Another advantage of this technology is being able to feed shear-sensitive materials.

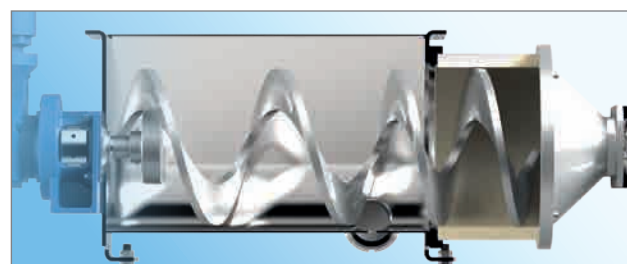
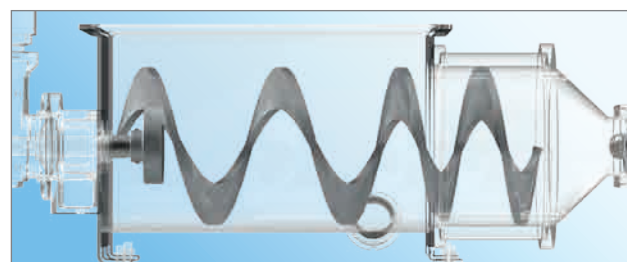

Section of the hopper, side view. Version with spherical feet



Tested quality

WANGEN PUMPEN Quality management is certified to ISO 9001.



Certified sustainability

The WANGEN PUMPEN environmental management is certified according to ISO 14001.



Your contact:

Pumpenfabrik Wangen GmbH

Simoniusstrasse 17
88239 Wangen im Allg.
Germany
www.wangen.com

Technical consultation: +49 7522 997-0
Service hotline: +49 7522 997-997
Spare parts: +49 7522 997-896