

Hygienic self priming and hopper feed pumps
**HYLINE, KB-SL, KL-SL, KL-RL,
KL-RF, KL-TL / KB-TL**

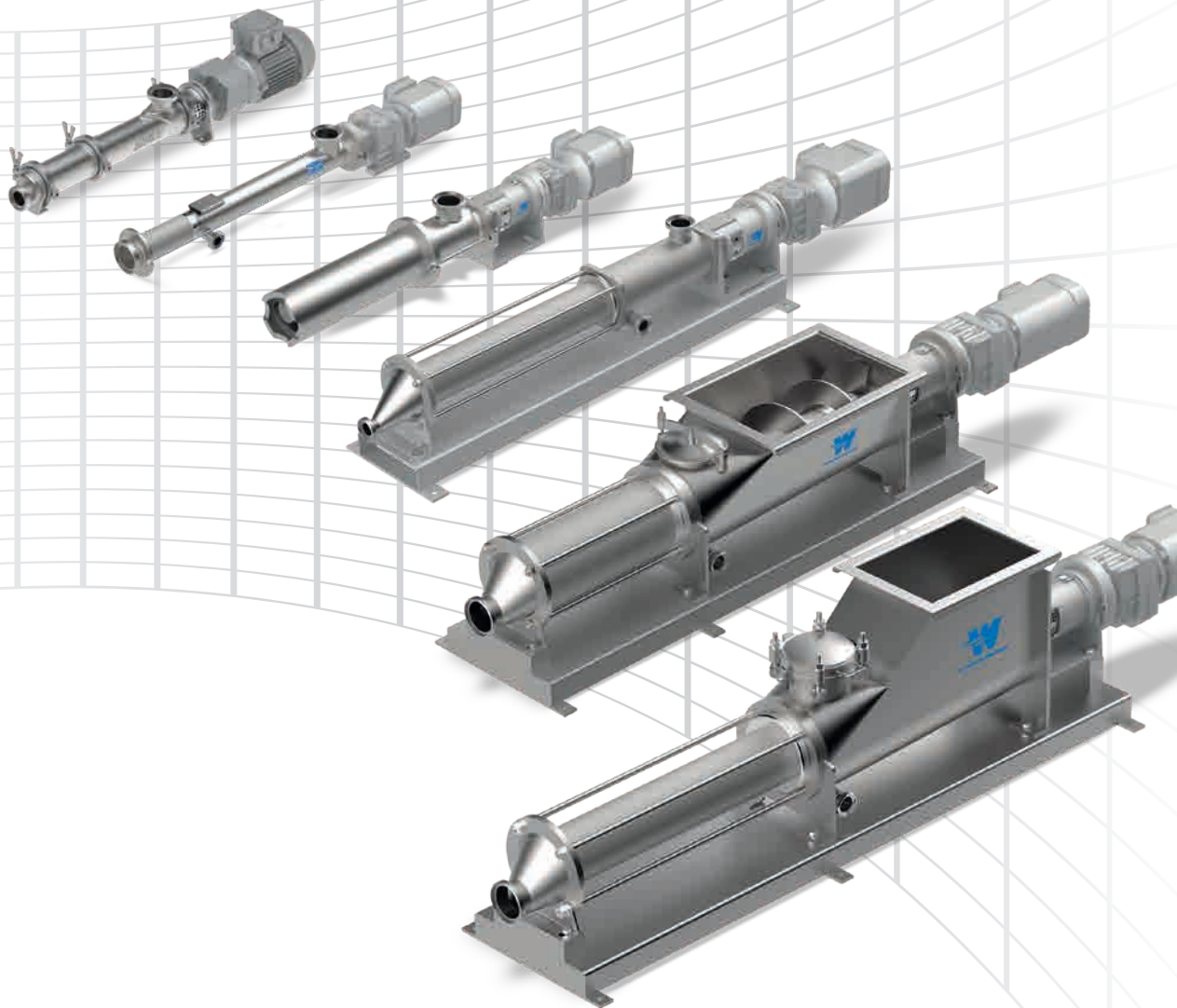

For hygienic pumping processes with
low to extremely high viscosity media

WANGEN hygienic self priming and hopper feed pumps

HYLINE, KB-SL, KL-SL, KL-RL, KL-RF, KL-TL / KB-TL,

A high degree of automation and fast product turnover are characteristics of the modern meat processing industry. Fruits and vegetables depend on freshness and quality. The confectionery industry works with different kinds of ingredients, which vary from viscous to sticky, may come in pieces or are sensitive to shearing forces. Diversity, good taste, and reasonably priced, that is the baker's ideal range of goods. Manufacturers of beverages must be able to compete in an increasingly globalised market, but at the same time offer the right product mix, quality, and price. The same applies to the milk processing industry.

As varied as the requirements, provisions, and areas of use may be, all the more individual are our solutions. However, one important point remains the same: satisfying the customers' highest quality requirements and specifications, especially in terms of hygiene. This has been a crucial aspect for us for a number of decades.

Technical highlights:

Flowrate 10 l/h – 150 m³/h,

Temperature – 30°C up to 140 °C,

Max. differential pressure 48 bar,

Viscosity up to 200.000 mPa·s.

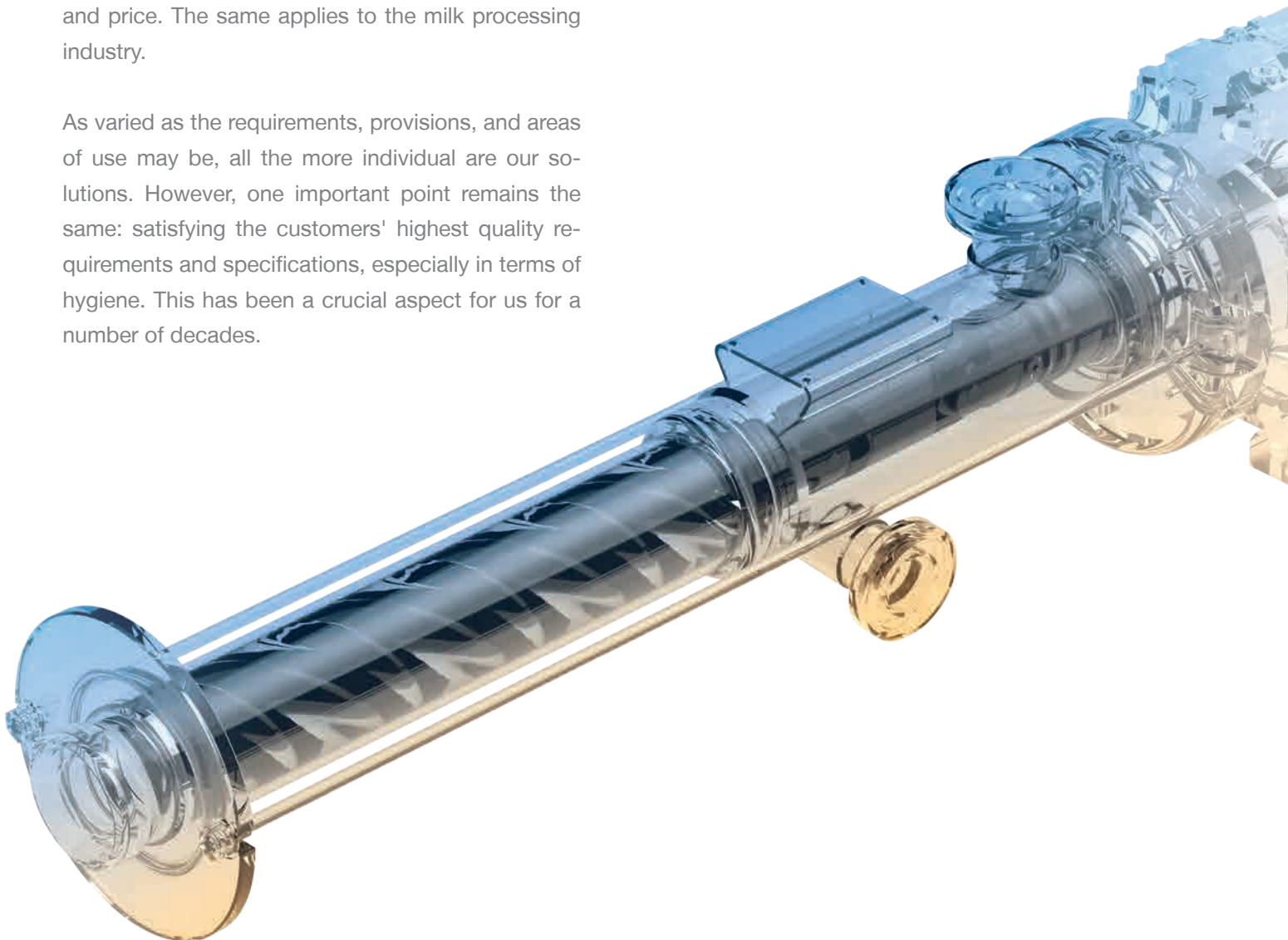

Applications

Conveying Materials

The progressing cavity pumps of the series KB-SL, KL-SL, KL-RL, KL-RF and KL-TL/KB-TL are typically used to pump the following mediums:

- Apples, pears, and other fruit
- Vegetables
- Grain and/or coarsely ground cereal
- Pastes
- Dairy products, such as butter, milk, yoghurt, ice cream, processed cheese
- Meat varieties and tofu
- Honey, caramel, gelatine, jam
- Confection, such as chocolate, liquid sugar, marzipan or waffle mass
- Beverages, such as fruit juices, beer
- Mustard, ketchup, soy sauce, tomato paste or mayonnaise
- Cosmetics, such as shampoo or soap



Properties

We always have the overall process in mind

We see ourselves not just as a supplier of individual components. Our objective is rather to find the best solution for the entire production process. We achieve this by exact observation and analysis of the overall process. You receive a solution to match your requirements that was precisely assessed and prepared by the specialists from WANGEN PUMPEN.

Whether complex or simple: We guarantee the best possible integration of our machines into your existing or new plant system. Here you will not only profit from our know-how in mechanical engineering but also from our many years of experience and the claim to provide our customers with the best possible, holistic answer possible, taking into account all relevant factors.



Properties

Highest standards of hygiene

We take our responsibility towards humanity very seriously, especially when it comes to hygienic pumps. For this reason, particular importance is placed on the highest precision and care in the production process at WANGEN PUMPEN. It is our goal to make the entry of bacteria and germs into our pumps as well as the living conditions as difficult as possible.

We achieve this by using consistent and uncompromising production according to the highest hygiene standards. This also includes the special design and surface characteristics of our pumps and their assemblies, which avoids producing deposits forming in the casing during the production cycle.

Our customers in the milk processing industry appreciate this because dairy products are especially vulnerable to micro-organisms in regard to the aspect of hygiene.

Thus, we are in a position to produce certain series of pumps according to the highest hygiene requirements of the EHEDG (European Hygienic Engineering & Design Group) for certified manufacturing procedures.



Properties

Construction Characteristics

Cutaway
model:
KL30-SL

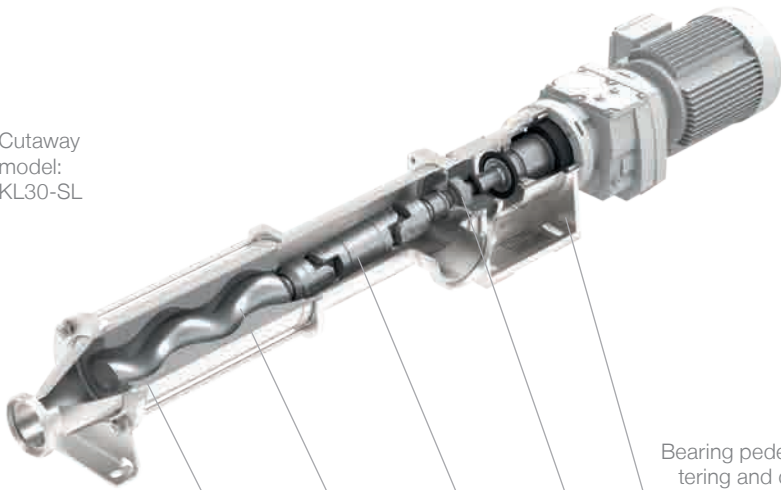

Bearing pedestal with self-centering and direct flange-fitting of the drive unit. This avoids damage to the gearbox.

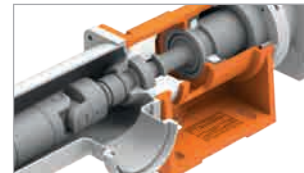

Main sealing material washed optimally within the product room as a mechanical seal.



Cardan shaft and joints in stainless steel, open design for ease of cleaning ability



Robust rotor of the highest quality from our own production available in various shapes



Stators in various shapes from our own production

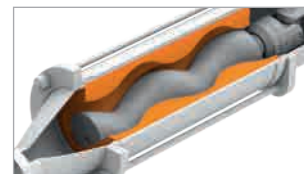

The construction of our pumps shows that they are consistently built for performance and reliability. For example, pumps of the KB-SL series are manufactured as a block construction, which completely suffices for media which e.g. exert only a lower impact on the pump, whereas the construction series KL-SL has a lot more alternatives in reserve, and can handle media ranging from highly abrasive and sticky properties to those which are particulate in nature.

Benefits

Maximum Variability

WANGEN progressing cavity pumps have a modular design. A variety of standardized parts is available for each series and enables each pump to be adapted to meet your specific pumping requirements. Regardless of whatever branch of industry you

work in, the medium to be pumped and your operational requirements: We offer the optimum solution for your application, regardless of the industry you work in, the medium to be pumped, and your operational requirements.

Maximum variability:

- Various construction sizes and rotor/ stator sizes mean more than 100 models of the compact pump with a delivery rate ranging from 10 l/h up to large pumps which can handle flowrates up to 150 m³/h.
- A availability of a large variety of designs and materials for casings, rotors, stators, seals, joints ensure that optimum adaptation to the medium to be pumped can be achieved.
- Our broad spectrum of flange connections and drive units assures that the best possible solution for your installation and available space can be found.

We would be happy to develop a solution for your specific design.

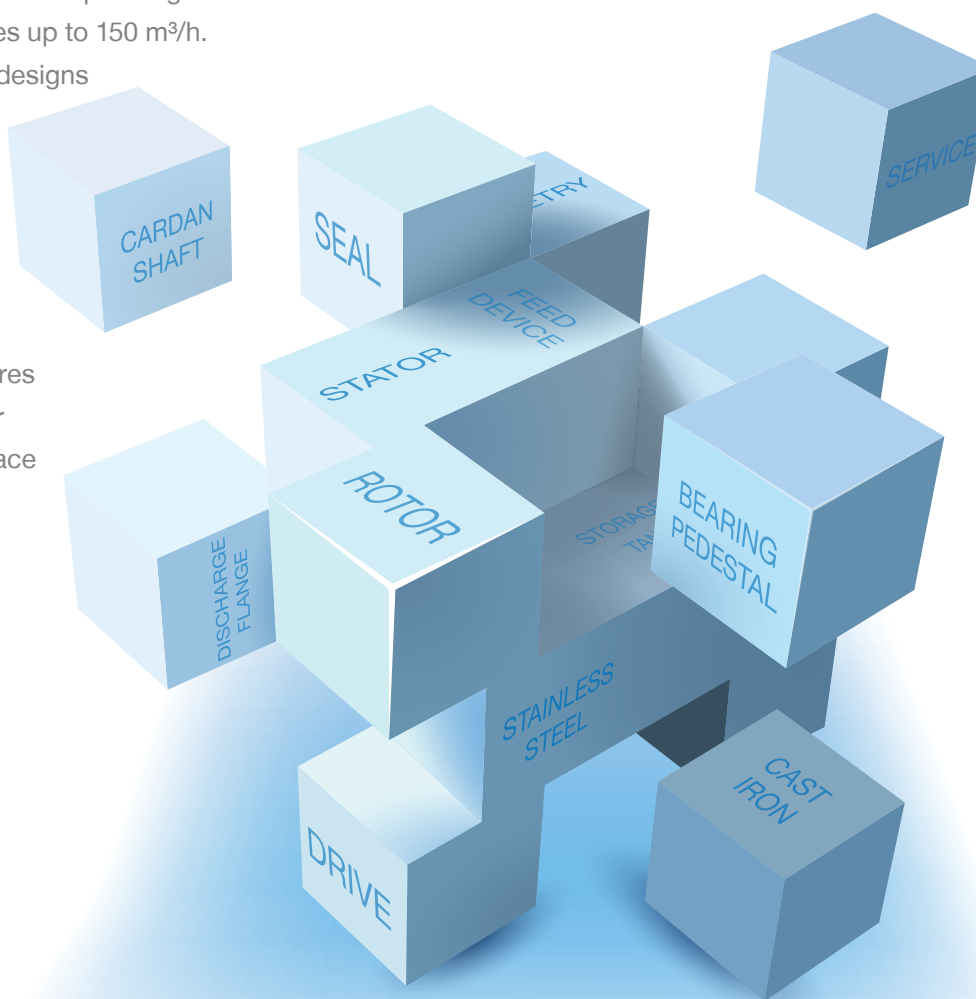

Benefits

Low Life-Cycle Costs

When purchasing a pump, we recommend that you carefully consider the operating costs as well as the costs for the initial outlay. Because maintenance costs, production downtimes and energy costs make up a considerable share of the total costs over the life-cycle of a pump.

In this case, a decisive advantage of our philosophy becomes apparent: in order to keep total costs as low as possible over the entire life-cycle of the pump, our approach is to restrict the frequency of maintenance to a minimum. This can be achieved thanks to the robust construction of our pumps, the use of high quality wearing parts and choosing a wear-resistant design for each pump.

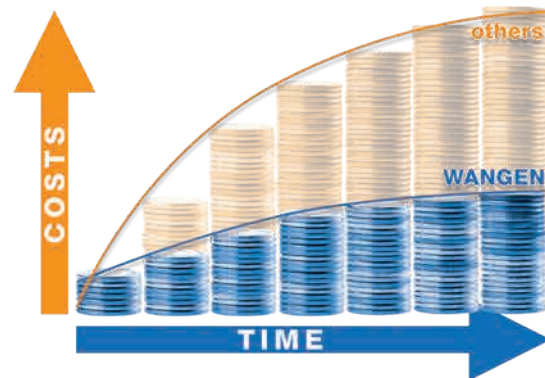

Because every breakdown that can be avoided saves you not only the costs for spare parts, but also the costs for maintenance work and production downtimes. In this way, you save on your pocket-book and your nerves.

Easy Maintenance

In order to ensure the high availability of plant and equipment, many of our customers want to service their pumps themselves. For this reason, our pumps possess large inspection covers, for example, or maintenance-free components, such as the flexible rod, especially when it comes to the aspect of hygiene. A change of rotor and shaft seal is also simple to perform, thanks to the good accessibility of the connecting bolts. The fact that WANGEN PUMPEN, amongst other things, comply with the highest



hygiene standards is also due to the optimised, low dead-space design and construction of our pumps over the decades.

Technical Data

Versions and Materials

There is a large selection of standardised construction parts available for the design of your standard suction pump. We provide economical and optimised pumping solutions that are tailor-made for your branch of industry and operating conditions.

- Casing, pressure and suction flange: Stainless steel 1.4301, stainless steel 1.4571
- Joints: stainless steel cardan joints, optionally with sleeve
- Seals: single and double-effect mechanical seals
- Drive unit: gearbox motors, hydraulic motors
- Stators: diverse NBR materials, FPM, silicon, EPDM, pressure-stable 'even wall' designs, solid substance stators made of POM
- Rotors and stators in up to 8 pressure classes and available as S-, L- and H geometric forms.

Options and Accessories



We offer a large selection of accessories which are perfectly matched to our product range, providing the ideal complement or adaptation to your individual requirements and allowing you to create your own customized solutions. We would also be happy to advise you here, as special solutions are of course also possible.

- Mounted on a baseplate or used as a mobile pump in the production plant
- Temperature and pressure sensors to prevent the pump running dry and the excessive build-up of pressure.
- Frequency converter to regulate the delivery volume
- Cardan joint with feed screw for pumping very viscous media.
- Pump manufactured in accordance with the ATEX guidelines for use in areas with potentially explosive atmospheres.

Spare Parts



By using original spare parts from WANGEN PUMPEN, we guarantee that the performance output of our pumps will be fully restored. With our decades of manufacturing competence, you will thus also be able to profit from our first class quality as a manufacturer and as a consequence ensure the long service life of your pump.

Technical Data

Performance Data HYLINE

The WANGEN HYLINE is designed by WANGEN PUMPEN to ensure optimal performance and operational reliability. The inner geometry of the housing is designed fully hygienically and, as is usual with WANGEN PUMPEN, suited to long life.

The flexible and maintenance-free joint is coated with elastomer and offers almost no weak spots for disposals of the media to be pumped. In order to enable the conveyance of a wide spectrum of media, a large selection of shaft seals are available for the HYLINE.

Pump size	Maximum free ball passage (mm)	Max. flowrate (m ³ /h)	Maximum differential pressure (bar)
20	26	0,02 – 6,6	20

elastomer-coated, maintenance-free joint

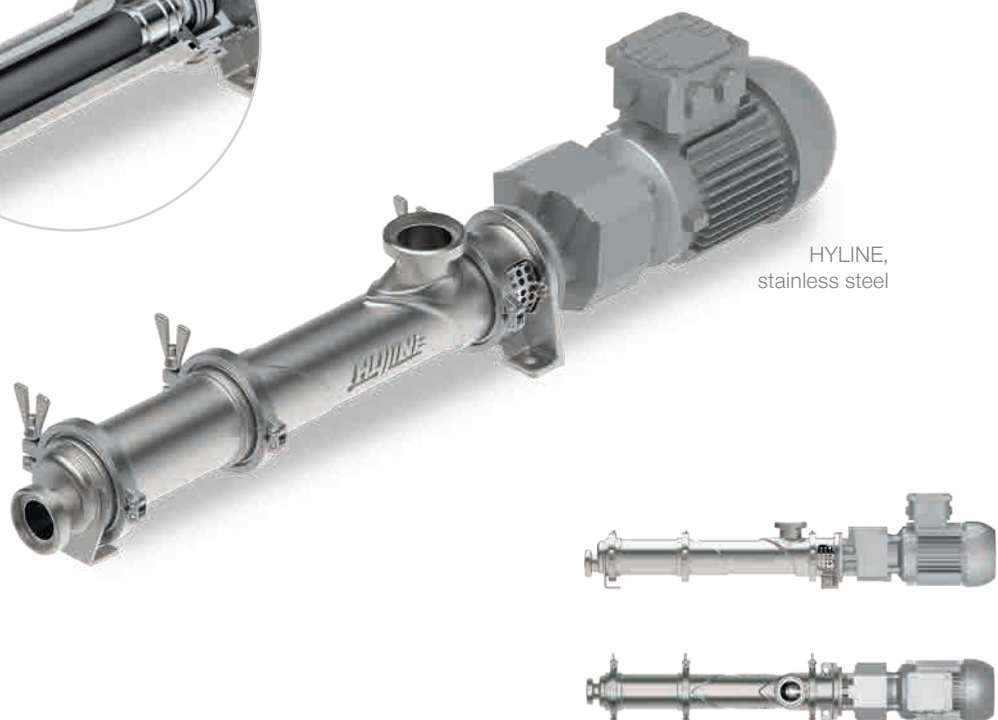
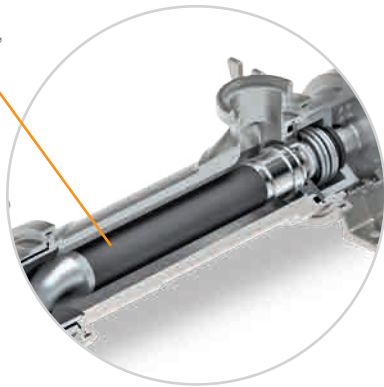

HYLINE, stainless steel

Technical Data

Performance Data KL-TL / KB-TL

The WANGEN progressing cavity pump type KL-TL / KB-TL is suitable as an immersion pump for pumping mediums out of tanks and basins. Regardless of the medium's consistency, it is conveyed as careful as possible without impairing its structure and quality. The joint connections retain an uniform diameter and ensure constant flow rates, the low-

pulsating and continuous pumping action of the media is independent of pressure and viscosity. A further benefit is the high level of operating safety. The configuration and length of the pump can be customized to meet the needs of the client.

Pump size	Maximum free ball passage (mm)	Max. flowrate (m ³ /h) at 350 min ⁻¹	Maximum differential pressure (bar)
20	24	0,04 – 2,1	12
30	51	0,3 – 32	12

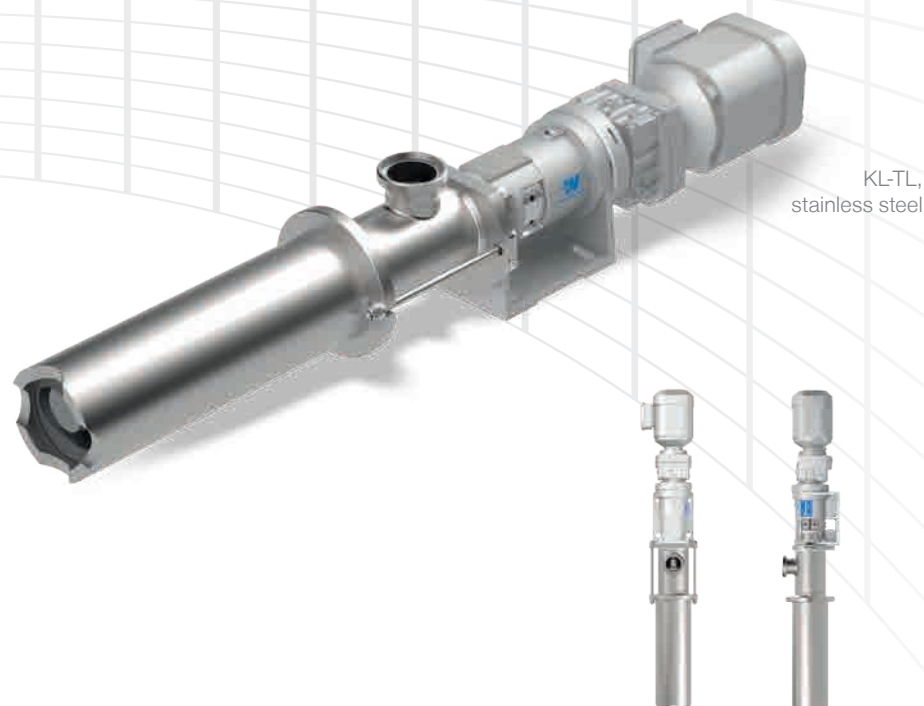

Technical Data

Performance Data KB-SL

The WANGEN progressing cavity pump type KB-SL Hygienic is a further development of the pump construction series for the food industry. In this area, where there is contact with the product, the stainless steel of the hygienic“ version, after grinding and electropolishing, has a surface roughness of $RA < 0.8 \mu\text{m}$. Further quality characteristics are the gentle

way the product is pumped, the dead-space and low stagnation space design, the high availability as well as the low maintenance requirement, the high dosing accuracy also at low rotational speeds and the extremely high level of safety in operation. The KB-SL is available optionally with one or two tangentially inclined cleaning connections.

Pump size	Maximum free ball passage (mm)	Max. flowrate (m^3/h) at 350 min^{-1}	Maximum differential pressure (bar)
20	24	0,01 – 4,6	48

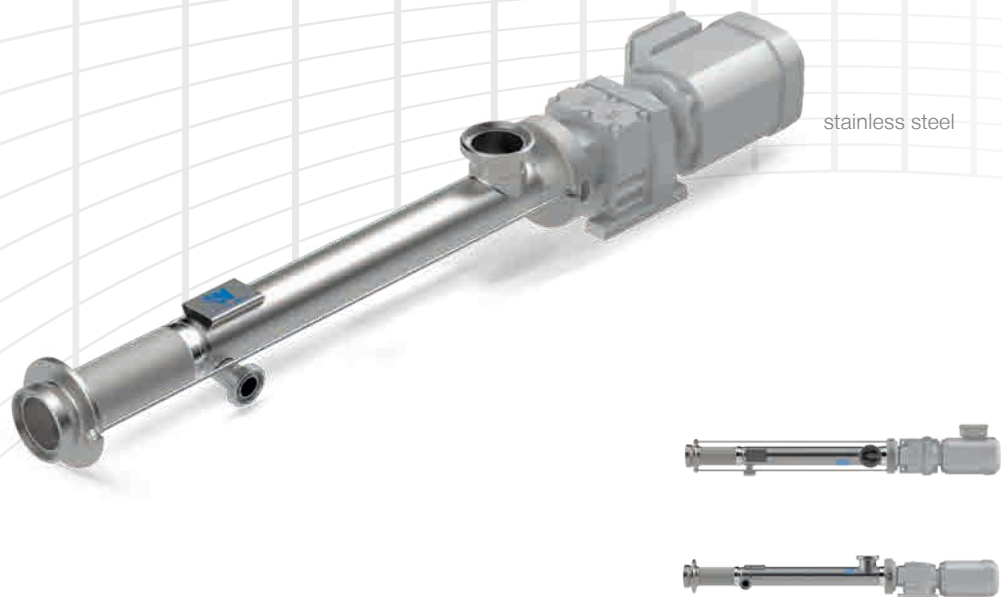

Technical Data

Performance Data KL-SL

The pumps of the KL-SL series convince with their ease of cleaning and low dead-space construction. In this area, where there is contact with the product, the ground, electropolished stainless steel of the EHEDG-certified version „Hygienic“ has a surface roughness of $RA < 0.8 \mu m$. Depending on the medium to be pumped, the pump can optionally be

operated in a heating or cooling mode. Further quality characteristics are CIP (Cleaning in Place), low pulsation, and continuous pumping independent of pressure and viscosity. It is able to cope with longer distances and big differences in height. The KL-SL is absolutely easy to maintain and also impresses by its high level of operational safety.

Pump size	Maximum free ball passage (mm)	Max. flowrate (m ³ /h) at 350 min ⁻¹	Maximum differential pressure (bar)
20	24	0,01 – 4,6	48
30	51	0,04 – 32	48
50	82	0,34 – 98	48
65	95	1,22 – 150	48

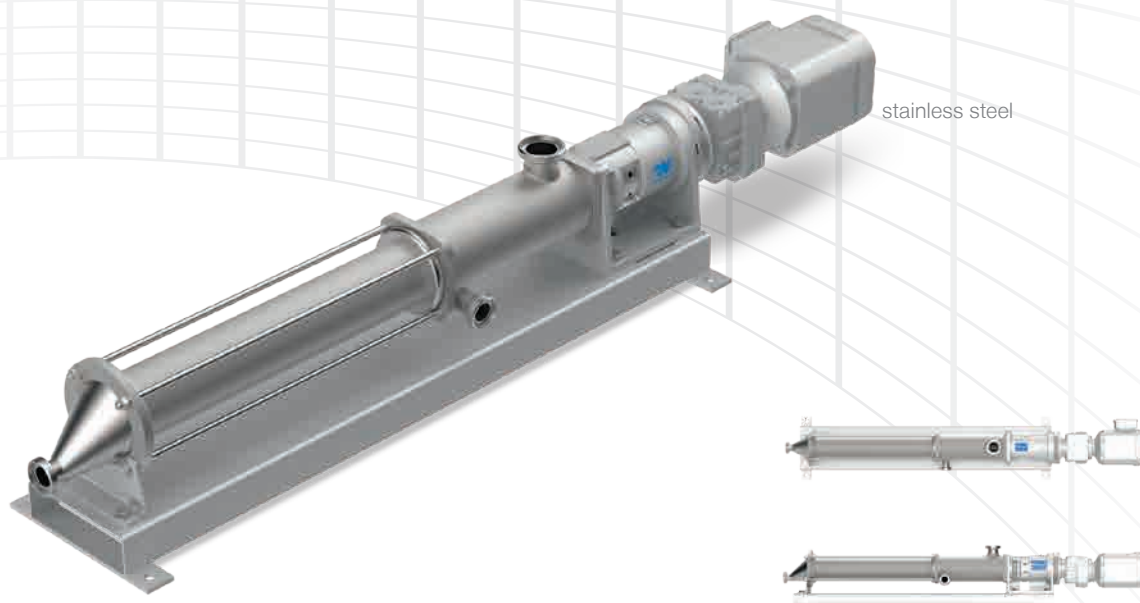

Technical Data

Performance Data KL-RL

Pumps of the series KL-RL allow almost pulsation-free pumping of mediums. The large hopper with screw conveyor has only a minimal dead space, despite the compact construction form, and avoids stagnation zones thanks to its special design. The stator is equipped with a funnel-shaped inlet for optimal filling of the feed chamber. In areas which

come into contact with product, the ground, electropolished stainless steel of the EHEDG-certified „Hygienic“ version has a surface roughness of $RA < 0.8 \mu\text{m}$. Depending on the medium to be pumped, the pump can be operated with heating or cooling options, and a variation using an attachable hopper is also possible.

Pump size	Maximum free ball passage (mm)	Max. flowrate (m ³ /h) at 150 min ⁻¹	Maximum differential pressure (bar)
30	51	13,5	48
50	95	45	48
65	95	65	48

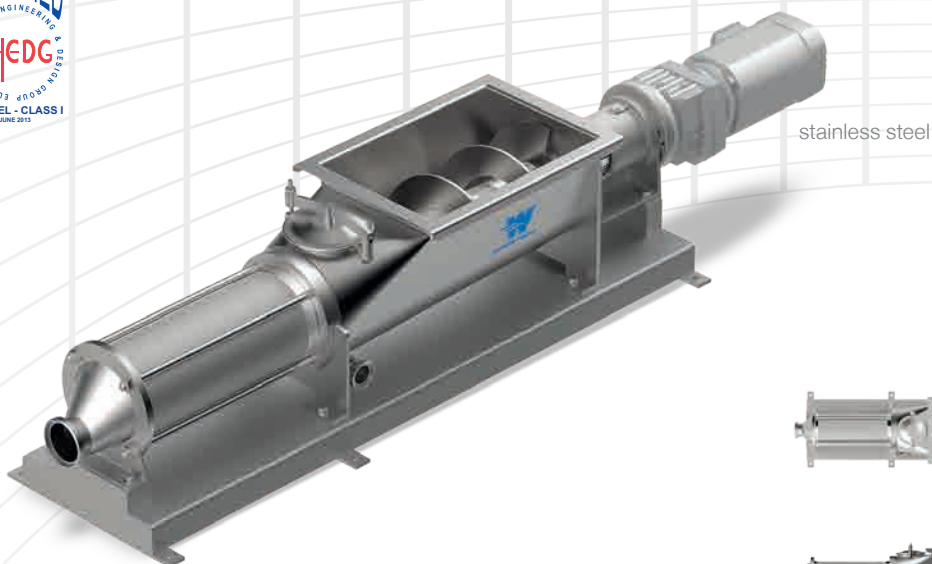

Technical Data

Performance Data KL-RF

Pumps of the series KL-RF have an inspection cover, a maintenance-free mechanical seal, which is independent of the rotation direction, and the discharge nozzle has a self-emptying design. The KL-RF is available with different rotor/stator geometric forms (S-, L- and H shapes). Products are pumped in a particularly gentle way and can be optionally

heated or cooled. A strength of the KL-RF is its use in plasticising blocks of fat or butter. Upon request, feed aggregates are also possible in special designs, as well as a version with an extension funnel.

Pump size	Maximum free ball passage (mm)	Max. flowrate (m ³ /h) at 50 min ⁻¹	Maximum differential pressure (bar)
30	51	4,5	48
50	95	15	48
65	95	22	48

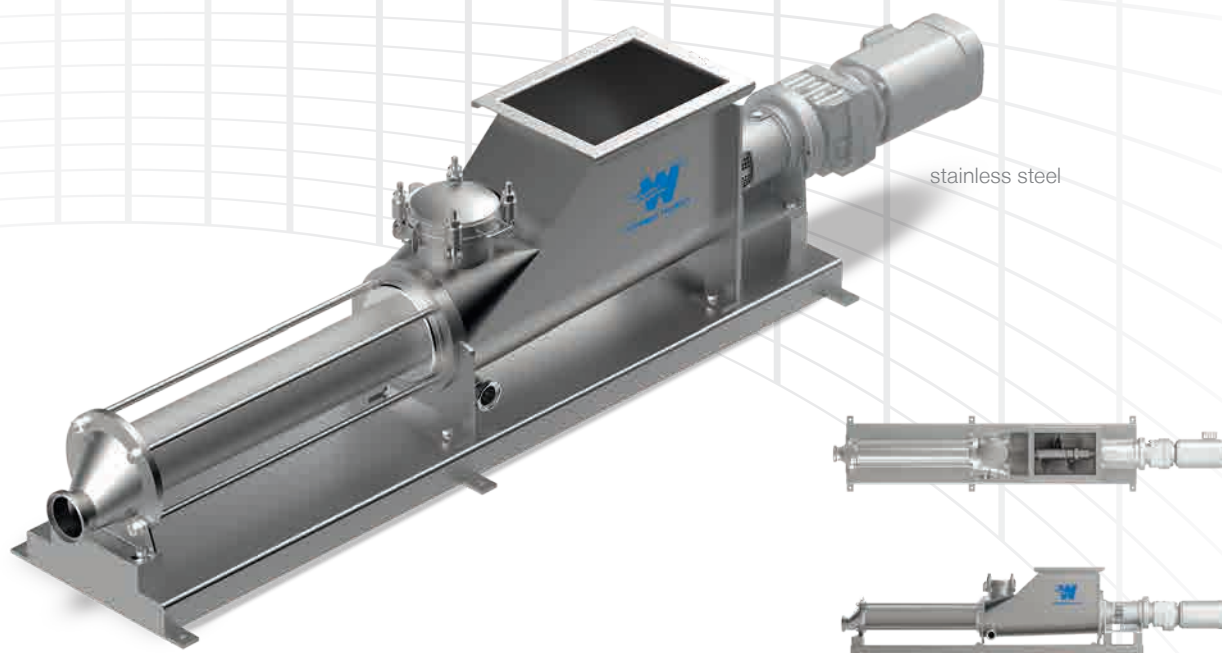



Tested quality

WANGEN PUMPEN Quality management is certified to ISO 9001.



Certified sustainability

The WANGEN PUMPEN environmental management is certified according to ISO 14001.



Your contact:

Pumpenfabrik Wangen GmbH

Simoniusstrasse 17
88239 Wangen im Allgäu
Germany
www.wangen.com

Technical consultation: +49 7522 997-0
Service hotline: +49 7522 997-997
Spare parts: +49 7522 997-896